



Oras Swea

INSTALLATION AND MAINTENANCE GUIDE



Water Is Worth Loving.



Accepterad
monteringsanvisning
2016:1

Contents

CZ Obsah	FI Sisällysluettelo	NL Inhoud	SE Innehållsförteckning
DE Inhaltsübersicht	FR Sommaire	NO Innhold	SK Obsah
DK Indholdsfortegnelse	IT Indice	PL Spis treści	UA Зміст
EE Sisukord	LT Turinys	RO Cuprins	
ES Contenidos	LV Saturs	RU Содержание	

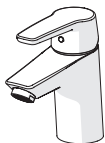

Technical data	4
Installation	5
Operation.....	7
Maintenance.....	7-10
Spare parts.....	11



Technical data	4
Installation	6
Operation.....	7
Maintenance.....	7-10
Spare parts.....	11

1510F (1510FK)

EN 817

I (ISO 3822) Oras lab.

50 -1000 kPa

0.1 l/s (300 kPa)(with flow controller)

max. +80°C

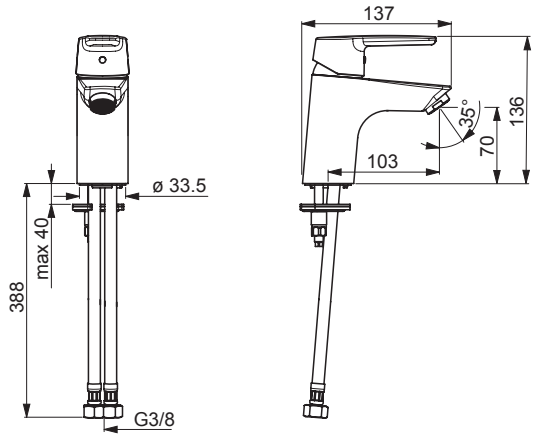

1441 KIWA Sverige 1913



1511F

EN 817

I (ISO 3822) Oras lab.

50 -1000 kPa

0.1 l/s (300 kPa)(with flow controller)

max. +80°C

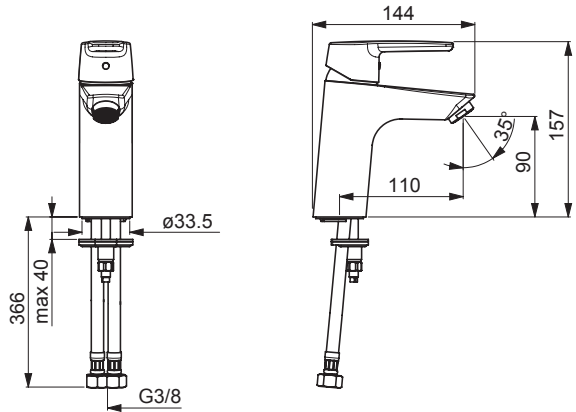

1441 KIWA Sverige 1913



1507F

EN 817

I (ISO 3822) Oras lab.

50 -1000 kPa

0.1 l/s (300 kPa)(with flow controller)

max. +80°C

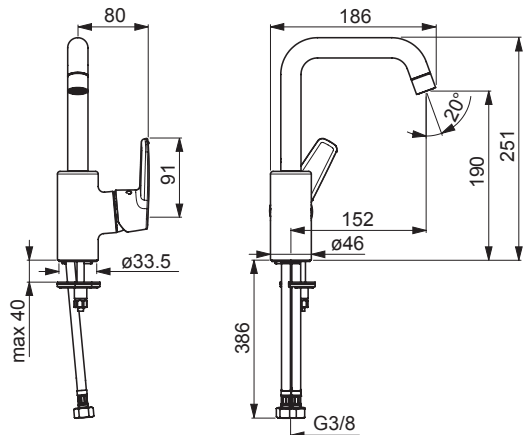

1441 KIWA Sverige 1913



Installation

CZ Montáž
DE Montage
DK Installation
EE Paigaldus
ES Montaje

FI Asennus
FR Installation
IT Montaggio
LT Montavimas
LV Montāža

NL Installatie
NO Montering
PL Instalacja
RO Instalare
RU Установка

SE Installation
SK Inštalácia
UA Встановлення

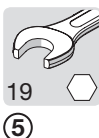
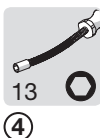
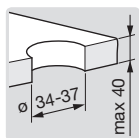
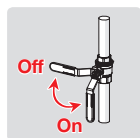

max.
1600 kPa

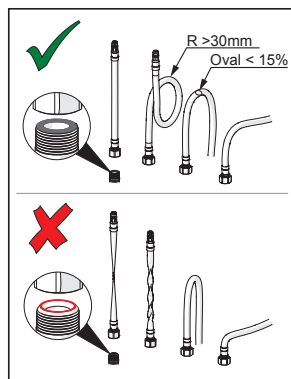
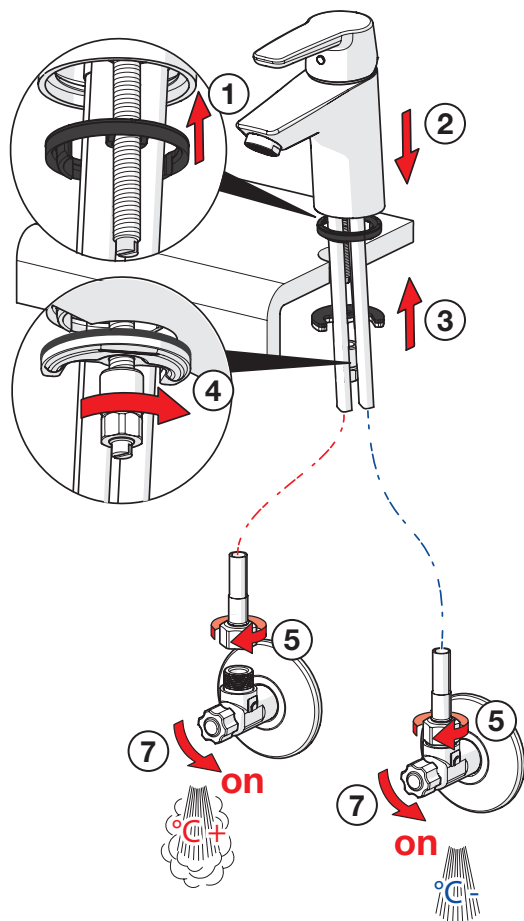

Installation

CZ Montáž
DE Montage
DK Installation
EE Paigaldus
ES Montaje

FI Asennus
FR Installation
IT Montaggio
LT Montavimas
LV Montāža

NL Installatie
NO Montering
PL Instalacja
RO Instalare
RU Установка

SE Installation
SK Inštalácia
UA Встановлення

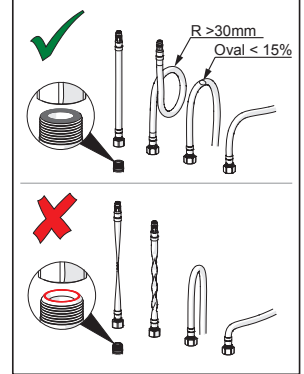
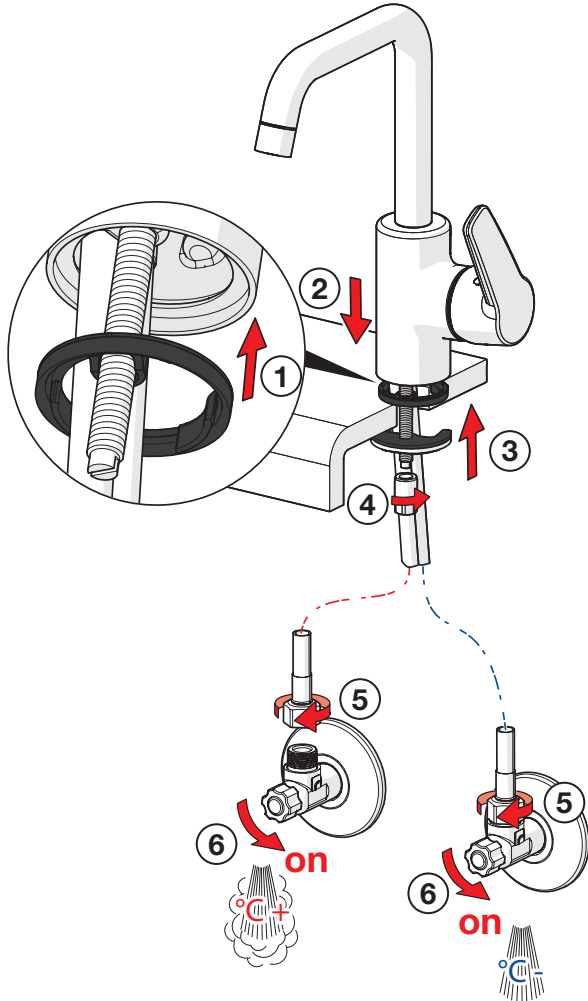
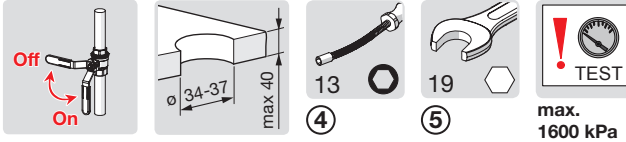

Operation

CZ Funkce	FI Toiminta	NL Bediening	SE Funktion
DE Funktion	FR Utilisation	NO Funksjon	SK Prevádzka
DK Betjening	IT Funzionamento	PL Działanie	UA Принцип дії
EE Toimimine	LT Veikimo principas	RO Funcționare	
ES Servicio	LV Darbības princips	RU Принцип действия	

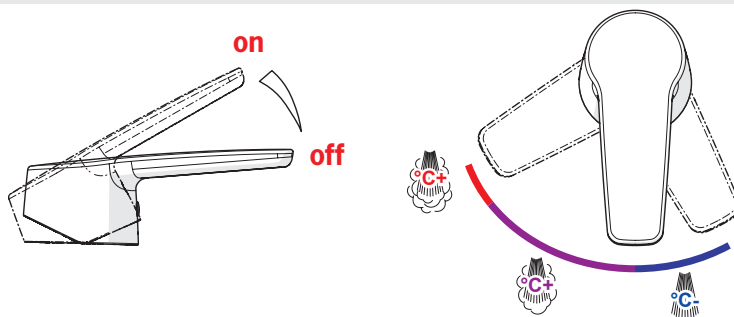

Limiting the flow rate

CZ Omezení průtoku	LV Ūdens plūsmas ierobežošana
DE Bergrenzung der Durchflußmenge	NL Begrenzing van de doorstroomhoeveelheid
DK Begrænsning af vandmængden	NO Begrensning av vannmengde
EE Vooluhulga piiramine	PL Ograniczenie wielkości strumienia
ES Limitación de la tasa de flujo	RO Limitarea debitului
FI Virtaaman rajoitus	RU Регулирование потока
FR Limitation du débit	SE Flödesbegränsning
IT Limitazione della portata	SK Obmedzenie prietoku
LT Vandens srovės reguliavimas	UA Регулювання потоку

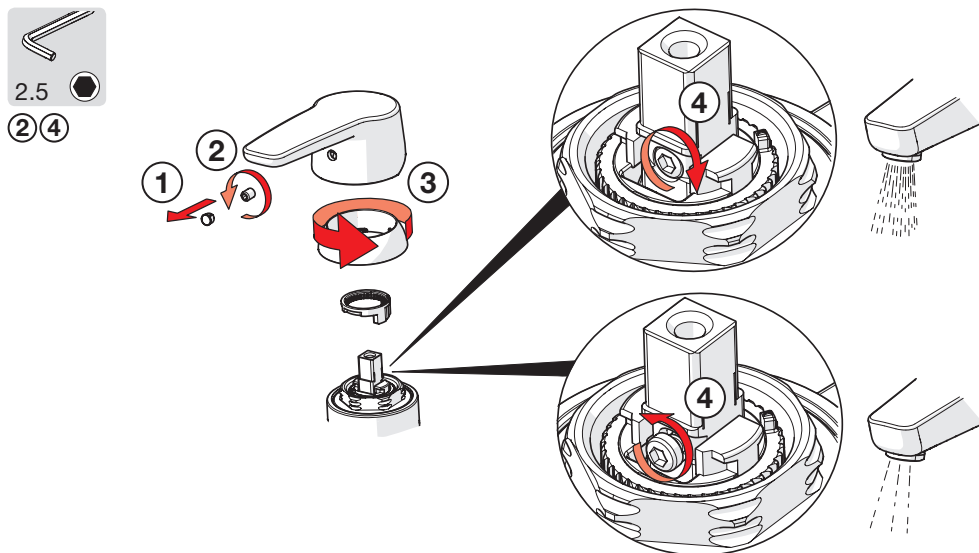

Limiting temperature

CZ Omezení teploty vody

DE Temperaturbegrenzung

DK Forindstilling af vandets max. temperatur

EE Temperatuuri piiramine seadeosast

ES Limitación de la temperatura

FI Lämpötilan rajoitus

FR Limitation de la température

IT Limitazione della temperatura

LT Temperatūros apribojimas

LV Karstā ūdens temperatūras ierobežošana

NL Perlator vervangent

NO Begrenzing temperatur

PL Ograniczenie temperatury

RO Limitarea temperaturii

RU Ограничение температуры в регулирующем блоке

SE Begränsning av vattnets max. temperatur

SK Obmedzenie teploty

UA Обмеження температури в регулюючому блоці



2.5

②

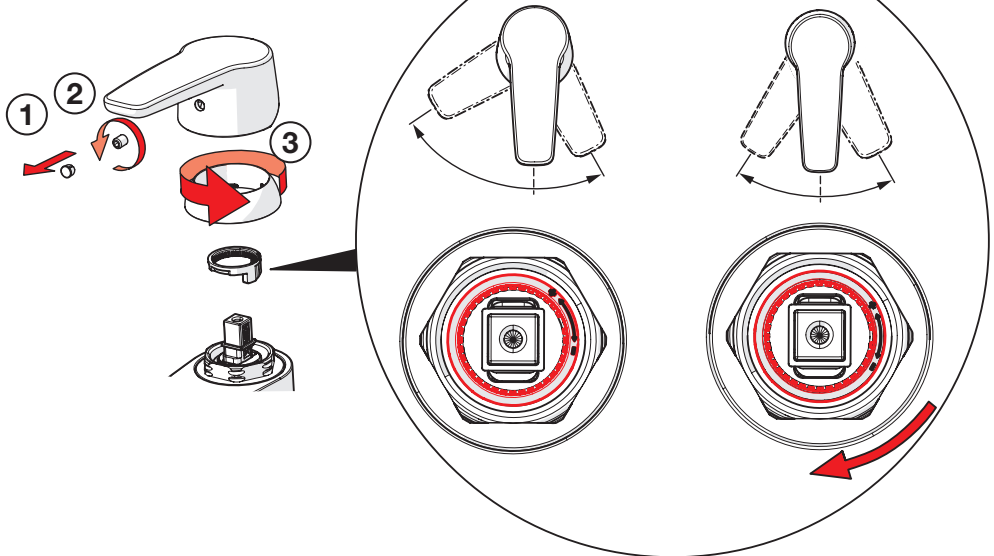

To change the cartridge

CZ Výměna kartuše

DE Ein- und Ausbau der Kartusche

DK Udsiftingning af reguleringskassette (unit)

EE Seadeosa vahetus

ES Montaje del cartucho

FI Säätöosan vaihto

FR Montage et démontage de la cartouche

IT Montaggio della cartuccia

LT Valdanciosios kasetės pakeitimas

LV Regulēšanas mehānisma kasetes maiņa

NL Vervangen van het keramische binnenwerk

NO Skifting av kassett

PL Wymiana modułu sterującego

RO Înlocuirea cartușului

RU Замена регулировочного блока

SE Byte av kassett

SK Výměna kartuše

UA Заміна регульовального блоку

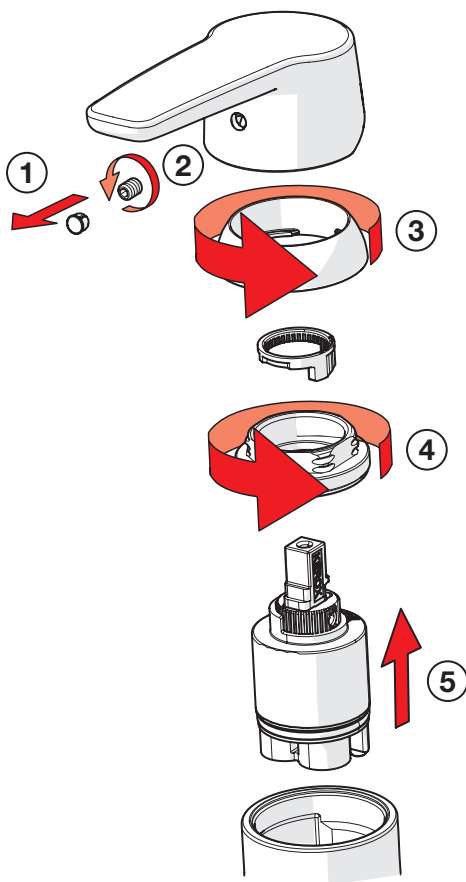
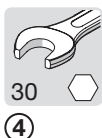
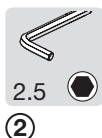
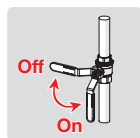

Cleaning the faucet

CZ Čištění baterie

DE Reinigung der Armatur

DK Rengøring af armaturet

EE Puhastamine

ES Limpieza de la grifería

FI Puhdistus

FR Nettoyage du robinet

IT Pulizia della rubinetteria

LT Maišytuvo valymas

LV Krāna tīrīšana

NL Reinigen van de kraan

NO Rengjøring av kranen

PL Czyszczenie baterii

RO Curățire

RU Чистка смесителя

SE Rengöring av blandarna

SK Čistenie vodovodnej batérie

UA Чищення змішувача

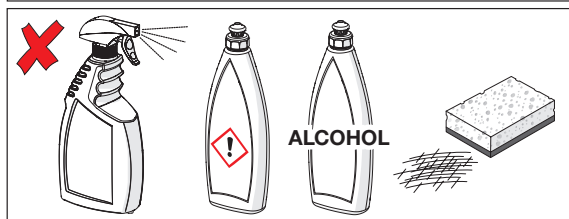
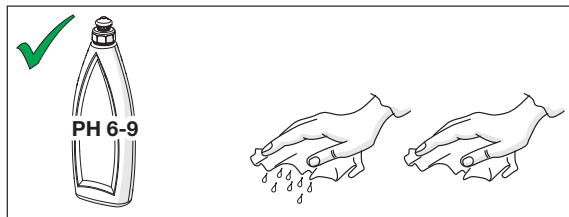
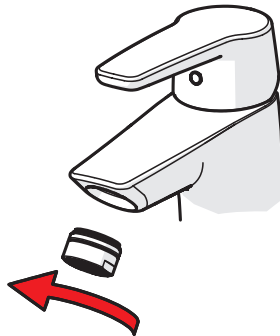

Spare parts

CZ Náhradní díly	FI Varaosat	NL Reserve- onderdelen	RU Запасные части
DE Ersatzteile	FR Pièces détachées	NO Reservedeler	SE Reservdelar
DK Reservedele	IT Pezzi di ricambio	PL Części zamienne	SK Náhradné diely
EE Varuosad	LT Atsarginės dalys	RO Piese de schimb	UA Запасні частини
ES Piezas de recambio	LV Rezerves daļas		

1510F, 1510FK, 1511F

- 1 1003170V
- 2 601967V
- 3 601968V
- 4 602672V
- 5 601974V
- 6 601970V
- 7 601985V

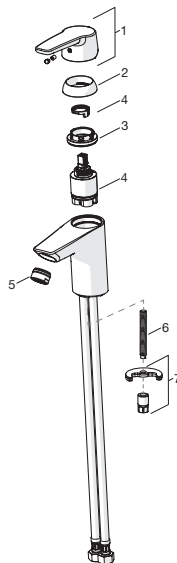

1507F

- 1 1001051V
- 2 1001071V
- 3 159670/10
- 4 1001098V
- 5 602672V
- 6 601968V
- 7 601967V
- 8 1003171V
- 9 601970V
- 10 601985V

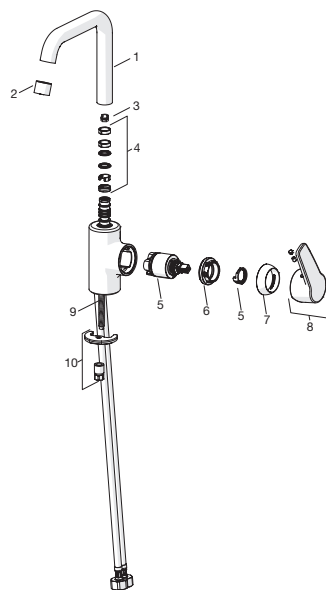

Oras Group is a powerful European provider of sanitary fittings: the market leader in the Nordics and a leading company in Continental Europe. The company's mission is to make the use of water easy and sustainable and its vision is to become the European leader of advanced sanitary fittings. Oras Group has two strong brands, Oras and Hansa.

The head office of the Group is located in Rauma, Finland, and the Group has four manufacturing sites: Burglengenfeld (Germany), Kralovice (Czech Republic), Olesno (Poland) and Rauma (Finland). Oras Group employs approximately 1400 people in twenty countries. Oras Group is owned by Oras Invest, a family company and an industrial owner.

ORAS GROUP
Isometsäntie 2, P.O. Box 40
FI-26101 Rauma
Tel. +358 2 83 161
Fax +358 2 831 6300
info.finland@oras.com
www.oras.com



Water Is Worth Loving.